

**Distributed By
JustCatering.Com Ltd**

10 Jessop Avenue, Norwood Green, Middlesex, UB2 5UY, UK

Tel/Fax: +44 (0)2088431712 Mobile: 07929291670

E-mail: sales@justcatering.com Web: <http://www.justcatering.com>

BAR - design guide

This guide is to establish best practice in how to construct a bar to interface with IMC stainless steel bar systems, top loading bottle coolers and glass frosters.

To achieve the best solution the following critical dimensions, design features and legal requirements must be followed:

- The bar must be a self supporting structure incorporating a service void, for service connections to be made.
- The underside of the bar top must be a minimum of 1060mm high
- To allow access to all services decor panels on the front of the bar need, if possible, to be removable
- The bar top should be between 400mm and 500mm wide.
- Back bar servery counter top to be the same height as the front bar top.
- The bar incorporates the required number of hand wash sinks.
- The bar complies with DDA (Disability Discrimination Act) requirements.
- If a glass washer is included within the bar area, consider the safe storage of chemicals.

Important information

Before starting to make decisions regarding the building of the bar, an approved layout of the IMC stainless steel bar equipment must be available.

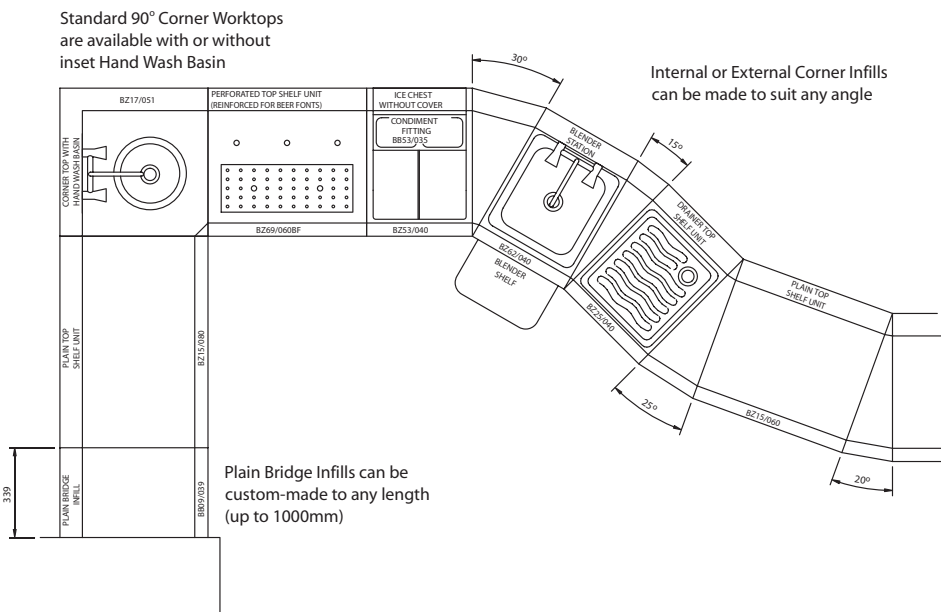

It is important to check the architects services drawing to ensure that the services (pythons, plumbing, drainage and electrics etc) enter the bar area in the correct position in relation to the bar layout and the final connection positions.

Consideration must also be given to any columns or other breaks in the bar that could affect the straight running of the services.



Bar construction using the IMC bar supports:

Fix IMC bar supports:

The bar support of the bar will support the bar top and the bar front, but will also carry all the services to the required positions along the bar. There are really two options, either use the IMC bar supports or construct them from wood. Using the IMC bar supports is easier and more cost effective in most applications. (See diagram)

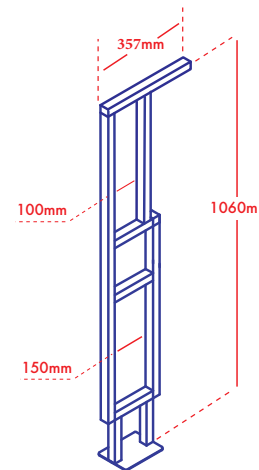

Stage 1:

Spacing of the bar supports is dependent upon the materials being used for the bar top and front panels. The heavier the material the closer together the supports need to be positioned, IMC recommend spacing between 600 mm and 1000 mm, using appropriate fixings.

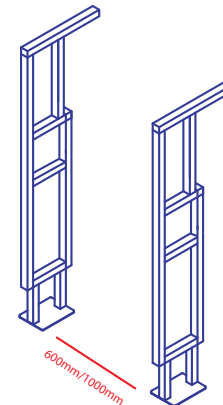

Stage 2:

A sub structure needs to be constructed and fixed to the front of the bar supports to hold the décor panels.

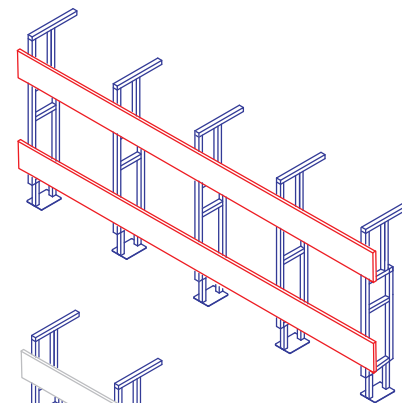

Stage 3:

Once positioned and fixed, a skirting board needs to be fixed to bottom inside section to allow for non-slip safety flooring to be fixed.

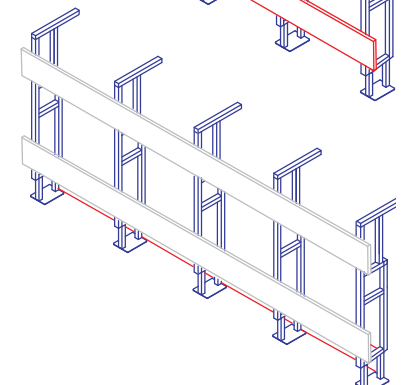

BAR - design guide

Stage 4:

Bar tops constructed from materials such as granite, natural stone and marble require a water resistant timber sub-structure fitted on top of the bar supports.

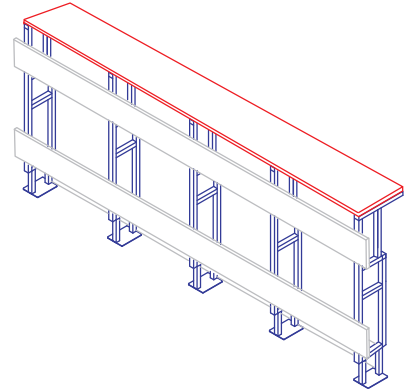

Any break or change of direction of the bar will require a bar support at the end and another to start the bar again, for example at a flap & gate, DDA section or at a column.

Maximum overhang of the bar top should not exceed 110mm from the end of the bar support to the edge of the bar top for Bartender (See Fig 2 & 3) and 80mm for F2.



Fig 2 (Bartender worktop overhang)

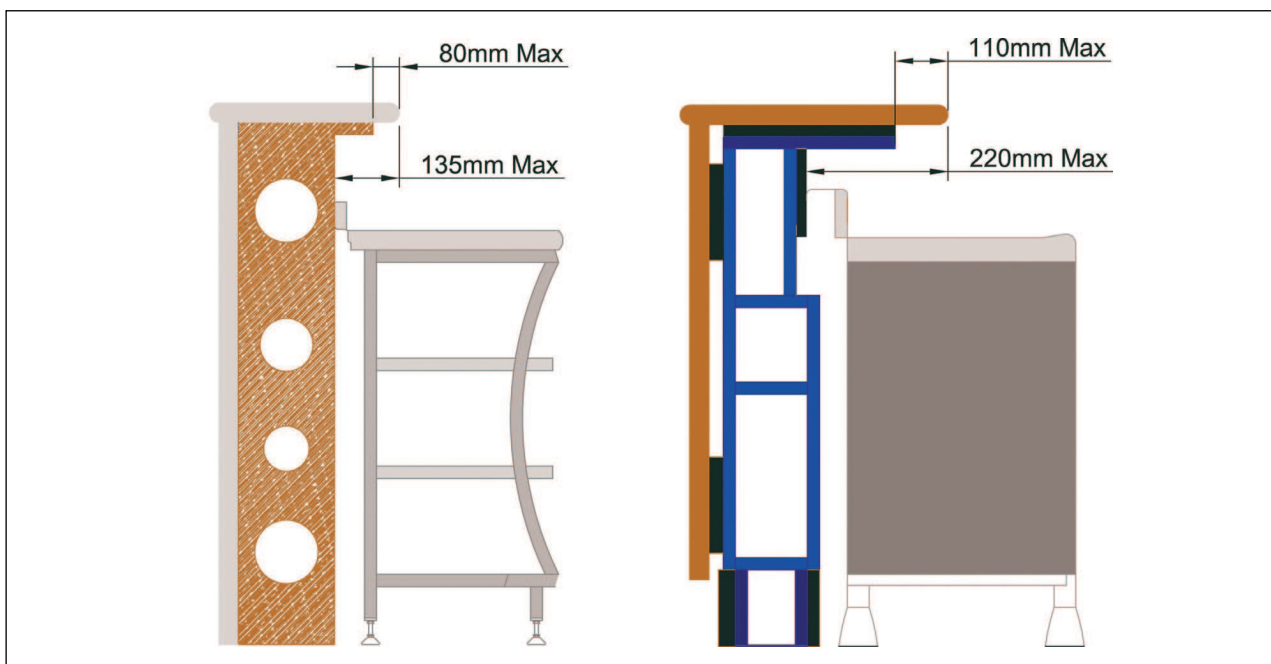

Fig 3 (F2 and Bartender overhang using timber and bar support frames)



First fix services

Install first fix services for the following, into the service void within the bar supports:

- ◆ Plumbing (drainage, hot and cold water feeds)
- ◆ Pythons (draught and soft drinks)
- ◆ Electrical
- ◆ Data (PDQ, telephone, tills, alarms)

Also install services required in the back bar servery areas:

- ◆ Electrical
- ◆ Data cables
- ◆ Plumbing

Flooring

Lay appropriate non-slip safety flooring.

Ensure that the floor is connected to the skirting board at the bottom inside section of the bar supports.

Back bar servery areas

Construct the back bar servery and upper back bar.

Ensure that the back bar servery bar height is the same as the front bar servery.

Second fix services

Position and T off the following services referring to the IMC stainless steel bar system layout drawing for positions of sinks, T offs and tills etc:

- ◆ Water supply to position for taps, ice machines, glass washers and drainage for sinks, drainer tops, ice chest, glass washers.
- ◆ Electrical for tills, power sockets, PDQ's, alarms, ice machines, glass washer, refrigeration etc.
- ◆ Beer and soft drinks pythons.

Also install services required in the back bar servery areas, for example refrigeration, coffee machine.

Upper service panel

Fix upper service panel on to bar supports, if possible this need's to be black so as to remain hidden. This will be used to fix the power sockets and other electrical services.

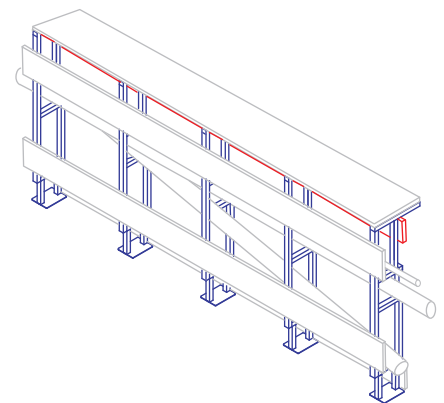
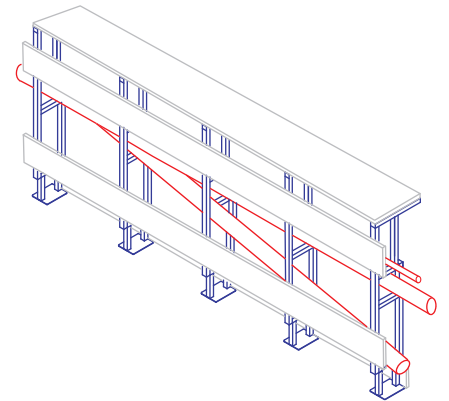

BAR - design guide

Final fix services

Fix the following services and connect (if applicable) ready for plug and go of electrical equipment.
Also pull the pythons through the upper panel in the relevant position, again refer to bar system layout drawings to ensure correct positioning.

- ◆ Power sockets
- ◆ Data sockets
- ◆ Telephone sockets
- ◆ Alarm

Install IMC stainless steel bar system

Install refrigeration in front and back bar servery areas

Fix bar top

Fix bar top to front and back bar servery areas.
Connect pythons to beer fonts, taps and post mix systems.

Final fix/connections

Connect all services to the front bar area, plumbing hot and cold water drainage for ice chest, drainer tops and sinks etc

Fit front décor panels to front bar and plinth to front bar. Complete back bar and upper back bar

Remove protective covering from equipment and clean with hot water

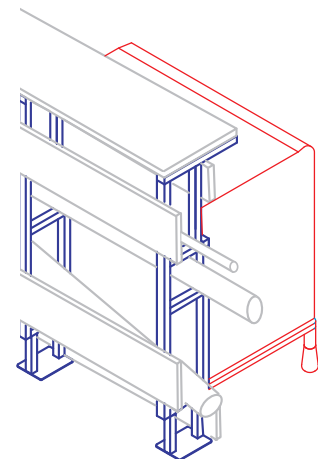

JustCatering.Com

**Distributed By
JustCatering.Com Ltd**

10 Jessop Avenue, Norwood Green, Middlesex, UB2 5UY, UK
Tel/Fax: +44 (0)2088431712 Mobile: 07929291670
E-mail: sales@justcatering.com Web: <http://www.justcatering.com>